



**EFFICIENTPOWER** EP  
MORE PRODUCTIVITY • LESS FUEL

# PUMA CVX

171 - 269HP MAXIMUM POWER - POWER MANAGEMENT  
131 - 228HP RATED POWER

**CASE IH**  
AGRICULTURE

PAGE 4	SIMPLICITY
PAGE 8	PRODUCTIVITY
PAGE 12	ECONOMY
PAGE 16	COMFORT
PAGE 20	EXPERIENCE & QUALITY
PAGE 22	SPECIFICATIONS





## FOR THOSE WHO DEMAND MORE.

Objectives change, needs change, markets change - but the number of hours in a day never does. And this is why we've unleashed the Puma CVX. A highly productive, versatile tractor that is easy to use and delivers everything you need to handle your daily tasks. Simplicity. Productivity. Economy. Comfort. Quality. The Puma CVX gives you more.

## Concise and easy to read

A-post instruments and performance monitor keep important functions and vehicle performance data centrally located.

## Ergonomically positioned controls

The Multicontroller™ armrest puts all the tractor's key functions in the palm of your hand.



# SIMPLICITY SAVES YOU MONEY.

Powered by the friendliest technology. The most helpful technology is technology you don't even notice, such as Automatic Productivity Management. APM optimises efficiency while you concentrate on your work. Get in and get started.



**Enhanced vehicle control** and additional productivity with programmable functions and settings, as well as notebooks and ISOBUS compatibility, provided by either AFS Pro 300 integrated into the armrest or via a separate AFS Pro 600 monitor.



**Headland Management Control™** - (HMC) can program and control up to 30 headland operations.



# SIMPLICITY PUT SERIOUSLY.

Feedback from customers clearly indicates that the Puma CVX is equipped with controls that are the easiest to understand and operate. We have done the sums and found that, compared to competitors' models in the same class, the Puma CVX will save you 28% on the time it takes to become fully acquainted with the control system. The fact is that a 28% time saving in the first month adds up to 83 hours, which when converted into the driver's wages (multiplied by the number of drivers), becomes serious money. Do the maths. Simplicity really adds up.



## A-post instrument display

The displays are clear, concise and easy to read. The integrated Performance Monitor provides additional feedback on tractor functions such as percent of slip, area worked and service reminders. The driver is also alerted of any warnings, with the engine shutting down automatically to protect your investment if need be.



Fitting a GPS receiver and the AFS Pro 600 colour touchscreen monitor will give you on-the-move performance mapping, and you can improve driving accuracy in combination with an AccuGuide auto-steering system.



Mechanical remotes are also available with the Multicontroller armrest allowing the operator to have the benefits of the intuitive ergonomics and the simplicity of the mechanical remotes.



## Multicontroller™ Drive Logic armrest

The Multicontroller - featuring drive logic - and the ICP intuitive control panel plus AFS Pro 300™ touch screen monitor, integrate all the tractor's functions into the armrest. Here you have everything you need in one place: speed selection, direction changes, throttle, Headland Management Control, electronic remote valves and front & rear hitch controls and much more. With a clear view of the instrument displays on the right-hand A post, the Puma CVX provides an operator-friendly environment that gets even a novice driver working effectively on day one.

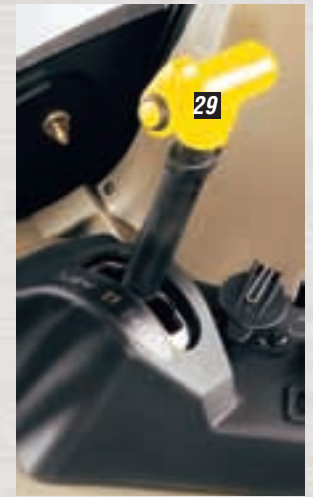
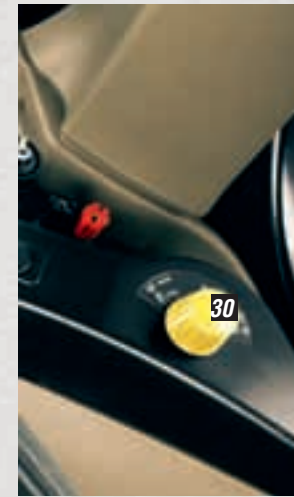

- 1 EcoDrive™ - Combines hand throttle and engine load limit control
- 2 Constant engine speed or Headland Management Control
- 3 Speed adjuster
- 4 EHC linkage raise/lower
- 5 Remote valve control
- 6 Powershuttle
- 7 Cruise control speed selector
- 8 AFS Pro 300™ touch screen monitor
- 9 Remote valve controls
- 10 Hydraulic motor mode and timer buttons
- 11 Joystick for remote valves
- 12 ICP™ Intuitive Control Panel
- 13 Lower position control front hitch
- 14 Front linkage raise/lower
- 15 Constant engine speed
- 16 ECO Fan
- 17 CVT transmission mode
- 18 Manual and Auto 4WD/Diff-Lock
- 19 Front axle suspension lock
- 20 Auto PTO
- 21 Slip Control
- 22 Headland Management Control
- 23 Hitch Ride Control
- 24 AccuGuide (if equipped)
- 25 EHC Position Control
- 26 EHC Draft control
- 27 EHC linkage raise/lower
- 28 PTO on/off
- 29 PTO speed selector (Puma 130 - 160 CVX)
- 30 PTO speed selector (Puma 170 - 230 CVX)
- 31 Slip Control
- 32 Encoder to adjust timer and flow control
- 33 Linkage upper limit control
- 34 Linkage drop rate control
- 35 Draft sensitivity control
- 36 Front linkage upper limit control

Relax, throttle back and reap the benefits of increased fuel efficiency without compromising on productivity.

Best in class specific fuel consumption through **Efficient Power EP**.

Source: DLG powermix official data

## 23% MORE PRODUCTIVITY.

Driven by top engine performance with Selective Catalytic Reduction (SCR) technology, Puma CVX engine power management delivers rated power - plus up to 23% more - easily handling heavy lugging jobs in the field and on the road as well as hydraulic lifting tasks with a hitch capacity of up to 10,460kg. Outstanding performance, season after season.





**Engine Power Management** delivers up to an additional 38hp. This is up to 23% additional performance.

The hydraulic system gives you **outstanding power and precise control**, with up to 170 litres per minute flow capacity and up to 10,460kg lift capacity.



# PRODUCTIVITY FIGURES.

With best in class fuel economy, best in class power management and best in class hydraulics, it figures that the Puma CVX delivers higher productivity. The Puma CVX sets productivity - 11.5% ahead of the competition.



## Engine

The Puma CVX series offers high performance common rail electronic ignition diesel engines ranging between 131 horsepower (96kW) and 228 horsepower (167kW). All engines are equipped with Selective Catalytic Reduction (SCR) technology, to comply with Tier 4a emission regulations, which come into effect for new tractors in 2011.

- Power Growth of an additional 21hp(CV) means you have an additional 10% performance available simply by throttling back to 1800/1900rpm.
- Engine Power Management delivers up to an additional 38hp. This is up to 23% additional performance and is available when driving faster than 15kph and in PTO applications.
- Constant Engine Speed allows the engine speed to be programmed to 2 different values for specific applications, be it pto, draft or hydraulic operations the speed will be constant regardless of load.
- Constant Power range means you have the same performance at 1500rpm as at rated speed, this allows you the opportunity to relax, throttle back and reap the benefits of increased fuel efficiency without compromising on productivity.
- Maximum Torque of 1160Nm allows you to relax and let the Puma CVX pull you.
- Drive at maximum road speed at fuel saving low engine revs.
- Service Intervals of 600 hours are the longest in the industry saving you time and money.

Case IH **Selective Catalytic Reduction (SCR)** technology improves horsepower, engine responsiveness, fuel economy and engine reliability, all whilst lowering emissions. This makes SCR the superior solution for Puma CVX engines.

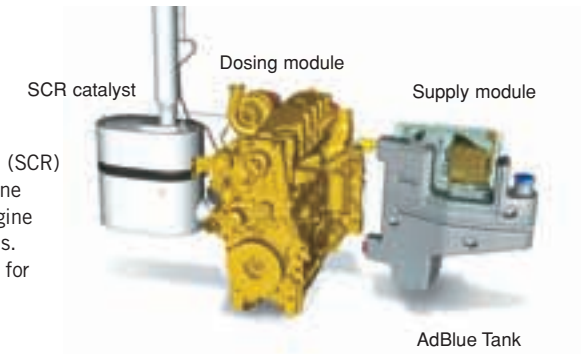

**Efficient Power.** The SCR system provides up to 14% lower fuel consumption on Tier 4A SCR engines when compared to DLG powermix average results.

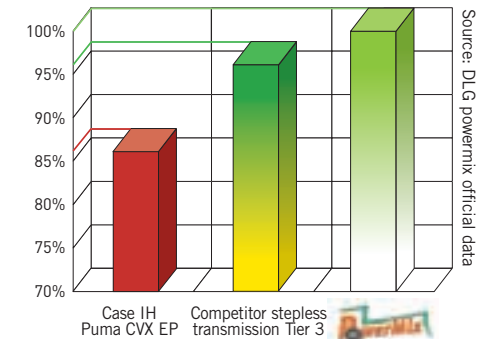

**Engine Power Management** maintains productivity by increasing engine power in tough conditions. Up to 38hp(CV) more can be delivered in addition to your tractors rated power.

Puma 230 CVX curves

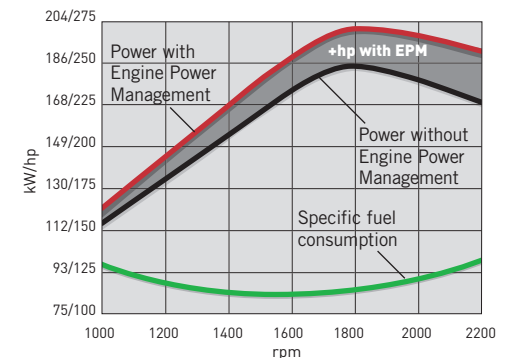



**Fender-mounted controls** for hitch, one remote and PTO make it safe and easy to hitch up implements single-handed.



**Puma CVX Productivity Advantage.** These figures show maximum power in draft application, maximum engine power management in PTO & transport applications, standard hydraulic flow and lift capacity in all applications.

## Hydraulics for precision power

Best in class hydraulics with a hitch lift capacity of up to 10,460kg. The Puma hydraulic system is powered by a variable displacement piston pump delivering up to 170 litres per minute for extremely responsive operation of on-board systems and remote-controlled machinery. Up to 9 remote valves can be supplied. Case IH LRZ front loaders are available factory fitted on the Puma 130, 145 and 160 models. Maximum lift up to 2800kg and maximum height at pivot up to 4260mm.

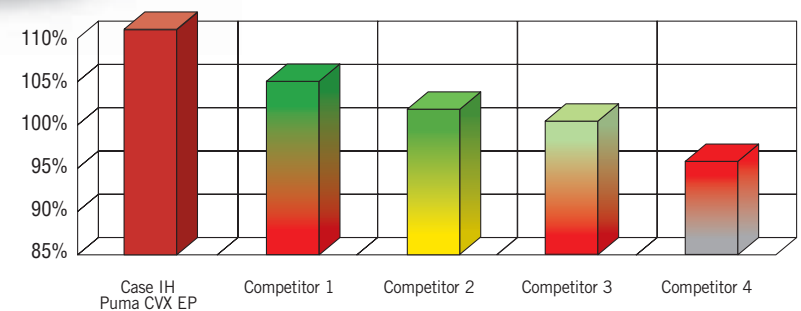

## ECONOMY. SAVE TIME, FUEL AND INPUT COSTS.

Rated “best in class” for fuel efficiency and also for running at reduced engine speed during road transport, the Puma CVX together with AFS Advanced Farming Systems saves you even more time and money by reducing overlaps in the field and optimising passes. Smart technology to save you serious money.



**Continuously variable transmission** drive between 0 and 50kph and and, thanks to APM, fuel consumption is reduced and operator comfort enhanced.

**Active Stop** holds the tractor stationary on a slope without applying brakes.

**Soft start-up PTO** gradually increases torque to ensure a smooth start-up and to protect implement drive shafts.



**Advanced Farming Systems** available on Puma CVX tractors are an essential ingredient for efficiency.

**ISOBUS**, a powerful communication tool to control ISOBUS compatible implements with the tractor integrated AFS Pro colour touch screen monitor.

**Automatic Productivity Management (APM)** looks after engine and transmission ratio to achieve greatest fuel economy for your desired driving speed.

## ECONOMY POSITIVE FORECAST.

APM - Automatic Productivity Management-works behind the scenes to reduce fuel consumption. By coordinating the engine, transmission and PTO with the Multicontroller and travel pedal, you get the ideal balance of fuel efficiency and power. In addition there are the simplicity and productivity figures.

If only the weather was as predictable as Puma CVX tractors.



### ECO Drive™ - the intuitive way to save fuel

Maintaining maximum road speed at reduced engine revs means less wear to the engine and fuel savings of 10%. That represents a substantial reduction in your fuel bill if your tractor is being used for transport work as well as in the field.

DKT™ Double Clutch Technology optimizes transmission efficiency to deliver a satisfyingly smooth ride and best in class fuel and power efficiency.





**AFS**<sup>TM</sup>



The **AFS Pro 300™** monitor screen is integrated into the armrest to provide performance monitoring, vehicle settings, video inputs and simultaneous command and control of ISOBUS-compatible machinery.



The Puma CVX and Case IH **AFS Advanced Farming Systems** provide the basis for fully automated precision farming with on the move data mapping and auto-guidance steering, saving you time, money and effort year after year.

**AccuGuide automatic steering systems** improve your precision farming accuracy up to 2cm pass to pass. Case IH offers the right solution for different needs: From manual guidance to fully vehicle integrated RTK guidance systems.

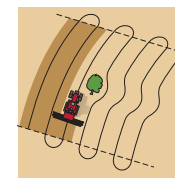
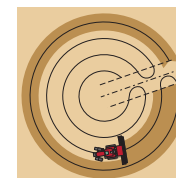
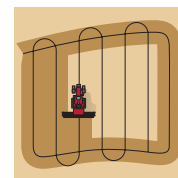

## COMFORT. THE QUIETEST CAB IN ITS CLASS.

It's quiet, it's extremely comfortable and it's designed to give drivers the highest level of protection and ease of operation for a full day of productivity and enjoyment out on the road, around the yard and in the field. Enjoy top productivity, in style, with the Puma CVX.

### **Everything in clear view**

Spacious Surround Vision cab features curved glass, low noise level and an unobstructed view of your surroundings.

### **Stay relaxed, stay alert**

Automatic climate control option lets you select the perfect temperature for continuous comfort.

**Suspended cab** is also available for the ultimate in ride comfort.

**Active front axle suspension** continuously monitors terrain changes and reacts in conjunction with hitch settings, brake status, acceleration, and more to create a neutral handling environment.









## **PREMIUM COMFORT.**

Less noise, less fatigue, 360° visibility. The Puma CVX features front axle suspension, cab suspension and a suspension seat to give the driver an ultra-smooth ride. With all the controls integrated ergonomically in the driver's seat armrest, clear all-round visibility and a surprisingly quiet operating environment, you are equipped for a relaxing and enjoyable day "behind the wheel".

## Top marks for Health and Safety

The Puma CVX features the latest Multicontroller armrest which is integrated into the seat to take the stress out of a long day in the field. The driver's seat is fully adjustable with lumbar support and there is an option of a Low Frequency Seat with heating. The steering wheel can be tilted and adjusted telescopically so you are always sure to adopt the healthiest driving posture.

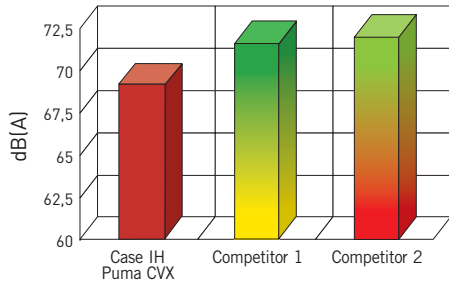

Noise levels of **just 69 dB(A)** are lower than any other tractor in this class!

With unsurpassed sight lines, the Puma CVX cab features **Surround Vision** with 5.87 square metres of glass and an optional high-visibility cab roof window for unobstructed views in all directions.



## Front suspension makes all the difference

Active front suspension improves ride comfort at the same time as providing more control. Less pitching is experienced when travelling at speed with mounted implements or manoeuvring with a loader. It has 105mm of travel and damping is then controlled via an advanced accumulator and regenerative valve system for a smoother ride. It also has automatic self-levelling according to load.

Puma CVX models 170, 185, 200, 215 and 230 have an “Active” suspension system which creates a neutral handling environment thanks to electronic sensors monitoring acceleration, gear changes, braking, terrain conditions, direction changes and hitch loads. The result is the smoothest ride with no more “nodding” or “pitching”.

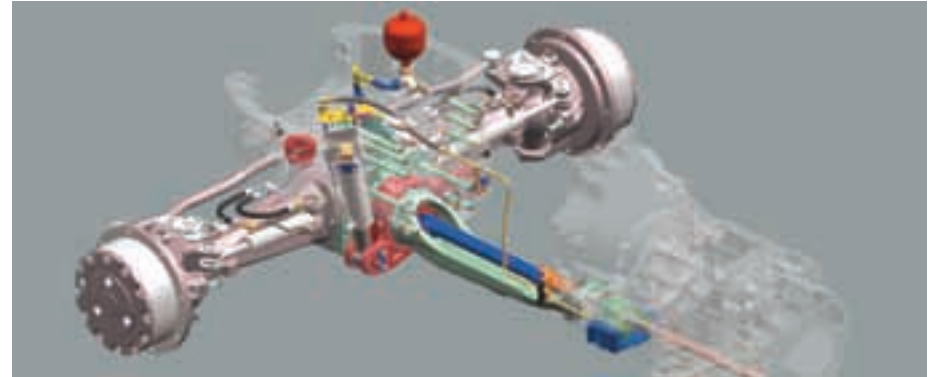

### Work day and night

Turn night to day with more than 10 lights available. A Xenon High-Intensity Discharge (HID) lighting package is available for even greater night visibility.



**Automatic climate control** option lets you select the perfect temperature for continuous comfort.



# EXPERIENCE AND QUALITY.

Good choice! Equipment availability is critical in farming because you have to schedule your work to fit in with tight weather patterns.

## Choose the tractor with built-in experience and quality

That is why it is important to choose a tractor that is a trusty workhorse as well as powerful and economical: Case IH has been developing reliable agricultural machinery for more than 160 years. The Puma CVX is built at the St Valentin plant in Austria, which celebrated its 60th anniversary of tractor production in 2007. Rigorous quality assurance procedures are implemented here and every single tractor built is subjected to a rolling road test to set up all the tractor's controls and make sure it is in perfect working order before being delivered to you. This is also the home of the continuously variable transmission, Case IH being the first manufacturer to develop this technology and integrate it into tractors at the end of last century. Case IH also took the lead in pioneering Automatic Productivity Management, well ahead of the rest of the field. **Choose the reassuring "Made in Austria" thoroughbred. Choose the Puma CVX.**



**Fuel-saving.** When Power Management is switched on, the Puma CVX reaches maximum torque at just 1400 to 1600rpm. Lower engine speed means you can work more quietly, but even more importantly - you save fuel. Florian Haas and Franz Xaver Prellinger, Gauting Hausen, Germany



**Easy operation.** You have an excellent overview of the individual controls and the touch-screen monitor is easy to use, even while you are driving. Andre Vorink, driver for Schoemaker, Itterbeck, Germany

## PARTS & SERVICE



**Maintain the productivity of your investment.** Case IH and its dedicated dealer network provide excellent support when you take delivery of your new machine and whilst it remains in your ownership. On the farm, you can rely on trained service professionals to maintain the productivity of your investment.

**Protect the value of your investment.** Behind every Case IH product stands an extensive European parts logistics organisation, stocking more than 700,000 part numbers for products old and new. Choosing to fit genuine Case IH parts will maintain the safety, value and performance of your original investment.



**MAX - the new premium service from Case IH.** We are always ready for you, around the clock, the whole year. Express delivery: when and where you need it. You get top priority during the season because your harvest cannot wait. The call is free. However some European Operators may apply a charge if the call is made from a mobile phone. For any information about charge rate, please enquire in advance from your provider.

**Extended protection programme.** Case IH is at your side giving you the best professional solution: Safeguard from Covéa Fleet. This is the personalised insurance coverage for your Case IH machinery. Please contact your dealer for more details. Subject to status and availability. Terms and conditions apply.

## DEALERS



**Skilled business advisor at your dealership. Demand more from your Case IH dealership.** Purchasing a stand-alone piece of new equipment? Keeping a whole fleet up-to-date? Whatever your size of operation, contact your local Case IH dealership for professional advice on finance and future-safe business investment. Case IH knows your farming needs.

## FINANCE



Your local Case IH dealer can work with CNH Capital to offer solutions that best fit your budget and business goals. At CNH Capital, we understand that no two farms or agricultural businesses are the same. That's why we work so hard to understand your needs first. We make it our job to know your business inside and out – your goals, your ideas and your unique outlook on the future. Then we can put together financial solutions and services that are right for you.



# SPECIFICATIONS

MODELS	PUMA 130 CVX	PUMA 145 CVX	PUMA 160 CVX	PUMA 170 CVX	PUMA 185 CVX	PUMA 200 CVX	PUMA 215 CVX	PUMA 230 CVX
<b>ENGINE</b>								
Number of cylinders / type	6 turbo, intercooled							
Capacity (litres)	6.7	6.7	6.7	6.7	6.7	6.7	6.7	6.7
Bore x stroke mm	104 x 132	104 x 132	104 x 132	104 x 132	104 x 132	104 x 132	104 x 132	104 x 132
Maximum power ECE R120 <sup>3)</sup> Power Management (kW/hp(CV))	126 / 171	138 / 188	149 / 203	160 / 218	172 / 234	184 / 250	191 / 260	198 / 269
Maximum power ECE R120 <sup>3)</sup> (kW/hp(CV))	109 / 148	120 / 163	130 / 177	138 / 188	149 / 203	160 / 218	172 / 234	183 / 249
... at engine speed (rpm)	1800 - 1900	1800 - 1900	1800 - 1900	1900 - 2000	1900 - 2000	1900 - 2000	1900 - 2000	1800
Rated power ECE R120 <sup>3)</sup> Power Management (kW/hp(CV))	118 / 160	129 / 175	140 / 190	151 / 205	162 / 220	173 / 235	181 / 246	191 / 261
Rated power ECE R120 <sup>3)</sup> (kW/hp(CV))	96 / 131	107 / 146	118 / 160	123 / 167	136 / 185	147 / 200	158 / 215	167 / 228
Rated engine speed (rpm)	2200	2200	2200	2200	2200	2200	2200	2200
Maximum torque - Power Management (Nm @ 1500rpm)	741	810	866	906	1019	1082	1120	1160
Maximum torque (Nm @ 1500rpm)	631	698	767	825	862	927	995	1089
Torque rise Standard / Power Management (%)	51 / 45	50 / 45	50 / 42	54 / 47	46 / 45	45 / 44	45 / 43	45 / 39
Fuel tank, standard/optional/urea (litres)	330/48	330/48	330/48	395/-48	395/-48	395/-48	395/-48	395/-48
<b>TRANSMISSION</b>								
Continuously variable transmission 50kph or 40kph ECO	●	●	●	●	●	●	●	●
Powershuttle	●	●	●	●	●	●	●	●
Rear axle diff-lock type	Multi disc wet plate with management system							
Service brake	Hydraulically operated multiple wet disc brake, self adjusting							
<b>FOUR-WHEEL DRIVE AND STEERING</b>								
Type	Electro-hydraulic with management system							
Front axle suspension	○	○	○	● Active	● Active	● Active	● Active	● Active
Steering angle (°)	55	55	55	55	55	55	55	55
Min. turning radius <sup>1)</sup> track setting 1829mm (m)	5.45	5.45	5.45	6.1	6.1	6.1	6.1	6.1
<b>POWER TAKE OFF</b>								
Type	Electro-hydraulic with Auto PTO control							
Speeds Standard / Option (rpm)	540/540E/1000 or 540E/1000/1000E (both with optional ground drive)			540E/1000 or 1000/1000E or 540/540E/1000/1000E				
Engine speeds Standard / Option (rpm)	1969/1546/1893 or 1592/1893/1621			1569/1893 or 1893/1700 or 1931/1598/1912/1583				
Shaft type	1 3/8" 21 splines / 1 3/8" 6 splines			1 3/8" 21 splines / 1 3/8" 6 splines / 1 3/4" 20 splines				
Front PTO with 1000rpm @ 1895 engine rpm	○	○	○	○	○	○	○	○

MODELS	PUMA 130 CVX	PUMA 145 CVX	PUMA 160 CVX	PUMA 170 CVX	PUMA 185 CVX	PUMA 200 CVX	PUMA 215 CVX	PUMA 230 CVX
<b>HYDRAULIC SYSTEM</b>								
Max. pump flow Std/Opt and system type main hydraulic (l/min)	125/140 PFC	125/140 PFC	125/140 PFC	150/170 PFC	150/170 PFC	150/170 PFC	150/170 PFC	150/170 PFC
System pressure (bar)	210	210	210	215	215	215	215	215
Control type	EHC with ride control							
Max. lift capacity (kg)	8257	8257	8257	10460	10460	10460	10460	10460
Max. number of remote valves mechanical / electronic	4 / 5	4 / 5	4 / 5	- / 5	- / 5	- / 5	- / 5	- / 5
Max. number of mid mount valves with electronic joystick	3 electr.	3 electr.	3 electr.	4 electr.	4 electr.	4 electr.	4 electr.	4 electr.
Category type	Cat II / III	Cat II / III	Cat II / III	Cat. III	Cat. III	Cat. III	Cat. III	Cat. III
Front hitch lift capacity (kg)	3568	3568	3568	3785	3785	3785	3785	3785
<b>WEIGHT</b>								
Minimum weight (kg)	5800	5800	6000	7300	7300	7300	7300	7300
Permissible total weight (kg)	11000	11000	11500	13000	13000	13000	13000	13000
Max. permissible weight front (kg)	4900	4900	4900	6000	6000	6000	6000	6000
Max. permissible weight rear (kg)	7300	7300	8500	9500	9500	9500	9500	9500
<b>DIMENSIONS <sup>1)</sup></b>								
A: Total length (mm)	4719	4719	4719	5017	5017	5017	5017	5017
B: Total height (mm)	3070	3070	3070	3090	3090	3090	3090	3090
C: Total width (across rear fenders with 150mm extension) (mm)	2470	2470	2470	2682	2682	2682	2682	2682
D: Wheel base (mm)	2789	2789	2789	2884	2884	2884	2884	2884
E: Height at centre of rear axle, highest point (mm)	2215	2215	2215	2239	2239	2239	2239	2239
F: Track setting front (mm)	1325-2285	1325-2285	1325-2285	1538 / 2260	1538 / 2260	1538 / 2260	1538 / 2260	1538 / 2260
rear (mm)	1430-2230	1430-2230	1430-2230	1530 / 2230	1530 / 2230	1530 / 2230	1530 / 2230	1530 / 2230
<b>STANDARD TYRES <sup>2)</sup></b>								
Front	480/70 R28	480/70 R28	480/70 R28	600/65 R28	600/65 R28	600/65 R28	600/65 R28	600/65 R28
Rear	580/70 R38	580/70 R38	580/70 R38	650/65 R42	650/65 R42	650/65 R42	650/65 R42	650/65 R42

● Standard Equipment    ○ Optional Equipment    - Not Available    <sup>1)</sup> With standard tyres    <sup>2)</sup> Other tyres on request    <sup>3)</sup> ECE R120 correspond to ISO 14396 and 97/68/EC

## DIMENSIONS

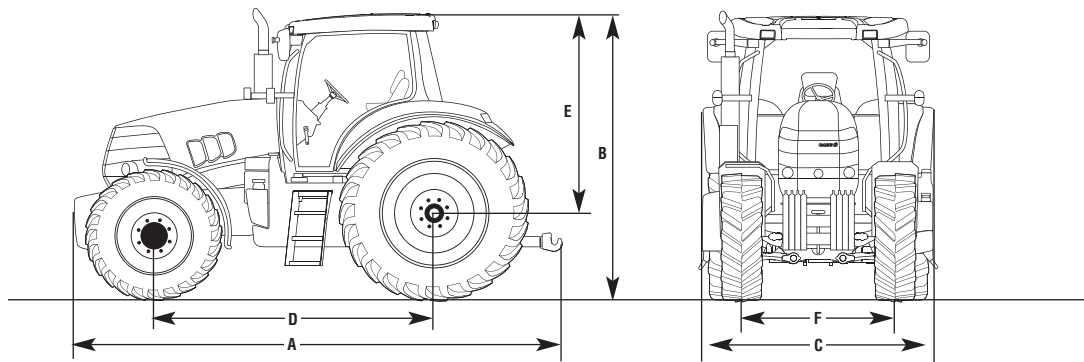



[WWW.CASEIH.COM](http://WWW.CASEIH.COM)



Safety never hurts! Always read the Operator's Manual before working with any equipment. Inspect equipment before using it, and be sure it is operating properly. Follow the product safety signs, and use any safety features provided.

This literature has been published for worldwide circulation. The standard and optional equipment and the availability of individual models may vary from one country to the next. Case IH reserves the right to undertake modifications without prior notice to the design and technical equipment at all times without this resulting in any obligation whatsoever to make such modifications to units already sold. Whilst every effort is made to ensure that the specifications, descriptions and illustrations in this brochure are correct at the time of going to press, these are also subject to change without prior notice. Illustrations may show optional equipment or may not show all standard equipment.

Case IH recommends **AGELLA** lubricants

CNH UK Ltd., Cranes Farm Road, Basildon, Essex SS14 3AD - © 2011 CASE IH - [www.caseih.com](http://www.caseih.com) - PUMA CVX-UK-BR - Free phone 00800 22 73 44 00 - Printed in Italy - 03/11 - TP01 - Cod. 10C0007/INB